

## GAS STATION LIGHT



### PRODUCT FEATURES:

- ❖ LUMILEDS LED, high luminous efficiency and long working life.
- ❖ High efficiency LED Driver, wide range input voltage AC120-277V;
- ❖ Die-cast alloy design, better cooling, light quality, LED Tj < 85°C
- ❖ Optical design, greatly improved the light utilization and evenness

MODEL #	
PROJECT:	
NOTES:	
DATE:	
PREPARED BY:	

### Additional Information:

- Power: 150W
- Input: AC 120-277V
- CCT : 5000K
- Output: 17800 LM
- Light Source: LUMILEDS
- Driver: SOSEN

### Structure Features:

- Shell Material: Alloy/PC
- Color: White
- Weight: 19.4 lbs.



### PRODUCT APPLICATIONS:

1000LED Gas Station Lighting Series can be widely used Fuel Pump Canopy Luminaires for Travel Centers, Truck Stops and Service Stations

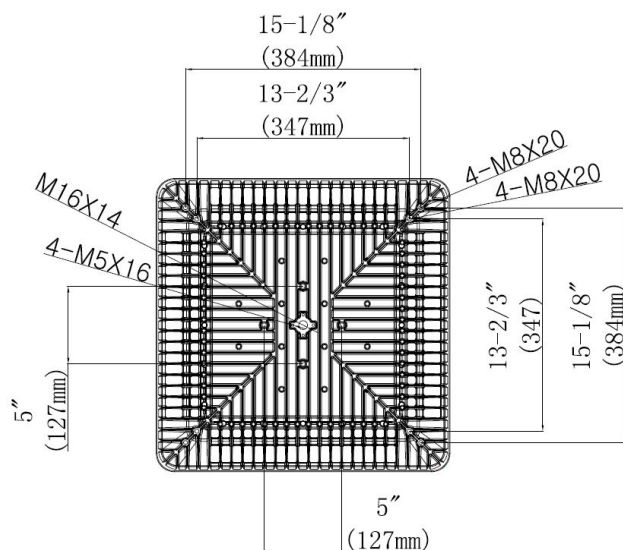
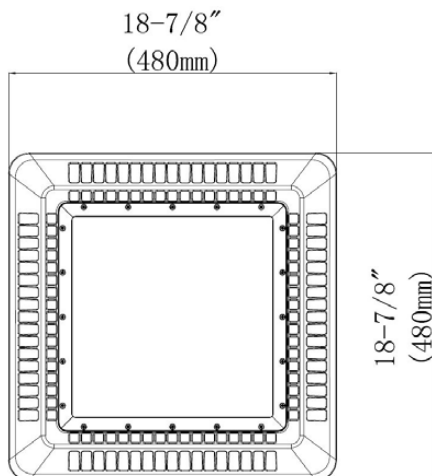
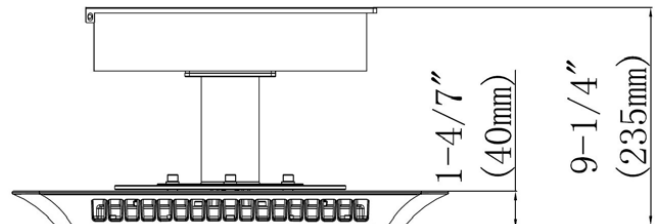

## GAS STATION LIGHT

### TECHNICAL PARAMETERS:

Type	1L-GSL15W27-XXK		
Power	150W	Lighting Angle	115°
Input Voltage	AC120-277V	Luminous Efficiency	115LM/W
Frequency Range	>47/63Hz	Working Life	>50000 hrs
Power Factor	>98%	Working Temperature	-30 - +50°C
Luminous Flux	17800 Lm	Storage Temperature	-40 -+80°C
Color Temperature	4000K/5000K/6000K	Protection Level	Wet Location/IP65
CRI	Ra>80	LED Chip Brand	Philips Lumileds

### LIGHT DISTRIBUTION:

Luminous Intensity Distribution

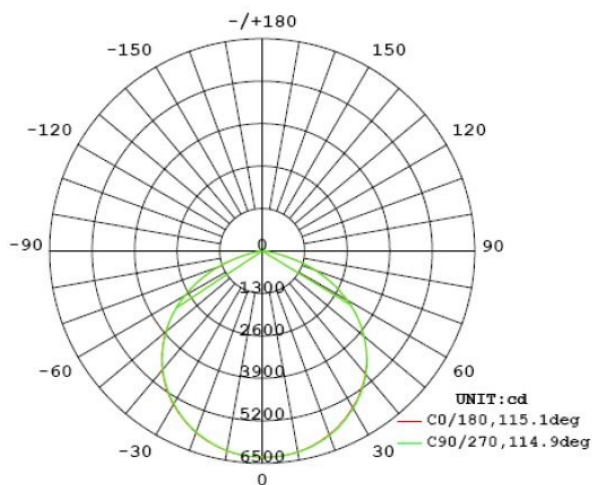

Angle: 115.00°. Flux out: 14133.0 lm.

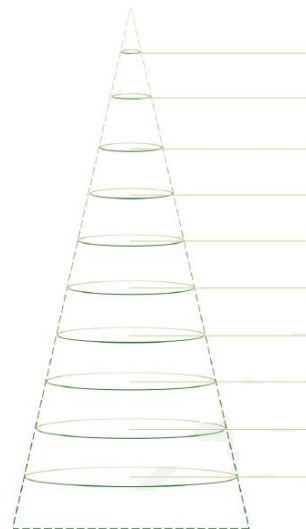

Height (m)	Diameter (cm)	E <sub>avg</sub> (lx)	E <sub>max</sub> (lx)
0.5	157.0	7026.0	25250.0
1.0	313.9	1757.0	6312.0
1.5	470.9	780.7	2806.0
2.0	627.9	439.1	1578.0
2.5	784.8	281.0	1010.0
3.0	941.8	195.2	701.4
3.5	1098.8	143.4	515.3
4.0	1255.7	109.8	394.5
4.5	1412.7	86.7	311.7
5.0	1569.7	70.3	252.5

## GAS STATION LIGHT

### ORDERING INFORMATION:

**EXAMPLE: 1L-GSL 15W 27-XXK**

1L	GSL	15W	27	50K	W	M
Company	Product	Power	Voltage	ColorTemp	Finish	Control
<b>1000LED</b>	<b>GSL</b> Gas Station Light	<b>12W</b> (120W) <b>15W</b> (150W) <b>20W</b> (200W)	<b>27</b> AC120-277V <b>48</b> AC200-480V	<b>40K</b> (4000K) <b>50K</b> (5000K) <b>57K</b> (5700K) <b>± 500K</b>	<b>D</b> White	<b>M</b> Motion Sensor (not available)

### PRODUCT CERTIFICATIONS:

