

MOUNTING GUIDES

I S: SLIP FITTER MOUNTING

Dimensions of the slip fitter

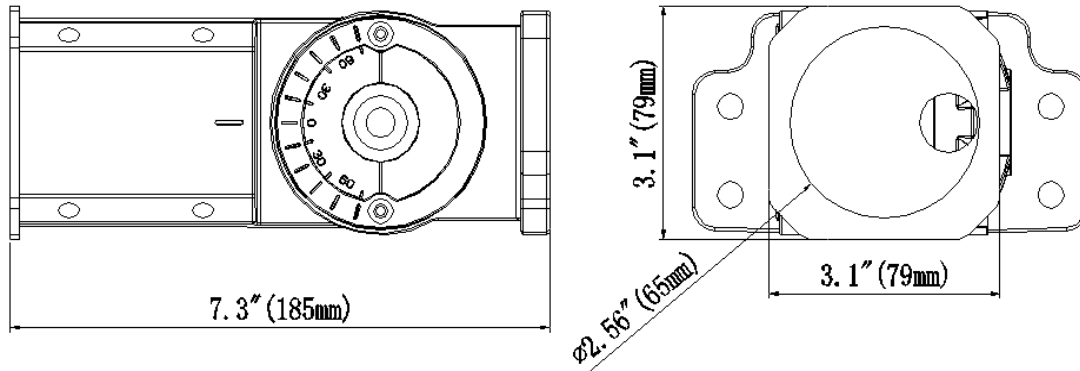

Step 1

Connect the AC wire, and then insert the arm of the slip fitter to the pole.

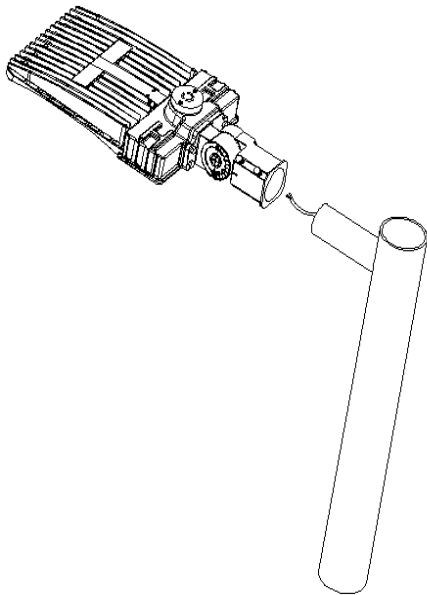

Step 2

Tighten the screws on the side of the arm and then power on.

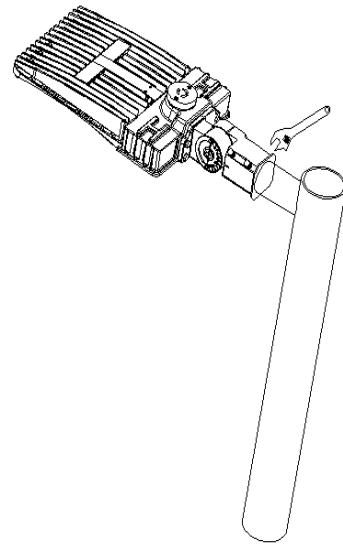

MOUNTING GUIDES

Slip fitter assembly drawing

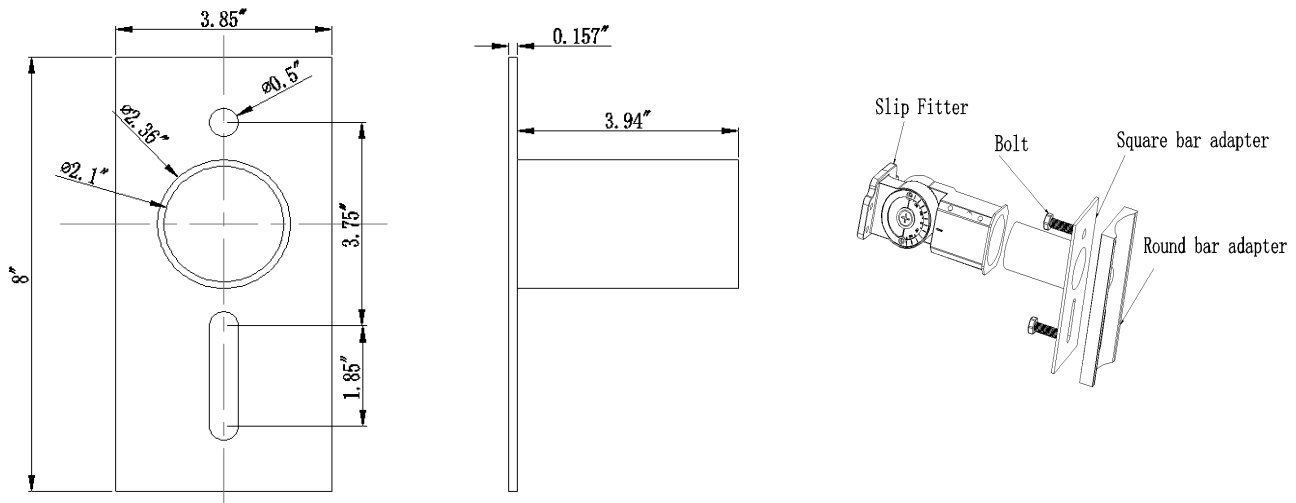

Step 1

Drill holes on the square pole corresponding to the holes on the square bar adapter, and use the bolt and nut plate to fix the fixture to the Adapter tightly.

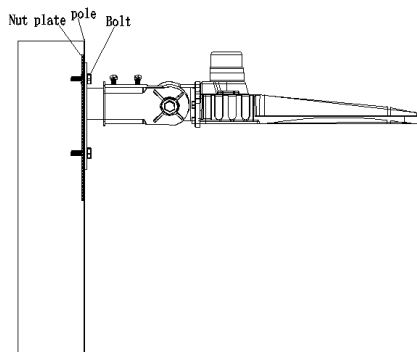

Step 2

Connect the AC wire of the fixture and tighten the water-proof gasket and cover plate on the square bar adapter by screws, then power on.

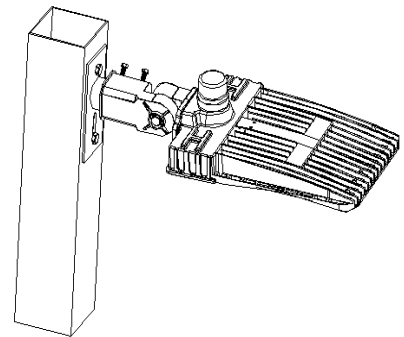

MOUNTING GUIDES

A2: SLIP FITTER MOUNTING FOR ROUND POLE

Step 1

Drill holes on the round pole corresponding to the holes on the Round bar adapter, and use the bolt and nut plate to fix the fixture to the Adapter tightly.

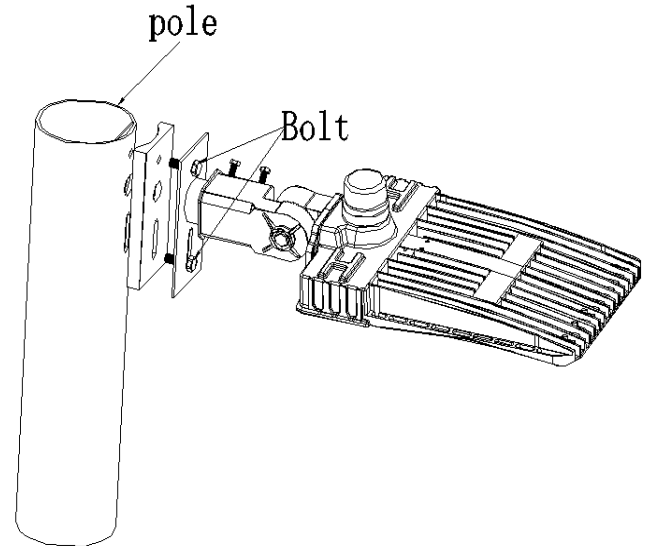

Step 2

Connect the AC wire of the fixture and tighten the water-proof gasket and cover plate on the square bar adapter by screws, then power on.

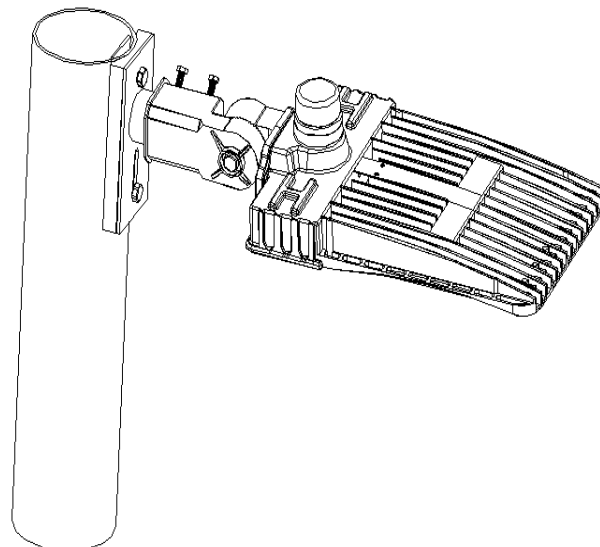

MOUNTING GUIDES

II T: TRUNNION MOUNTING

Dimensions of the trunnion

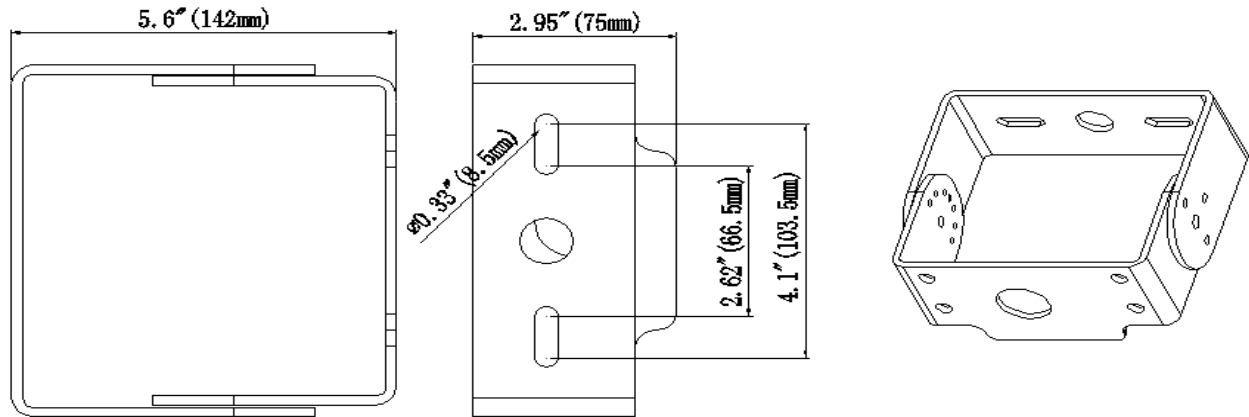

Step 1

Drill two holes on the wall corresponding to the holes on the trunnion, and knock expansion screws into the holes.

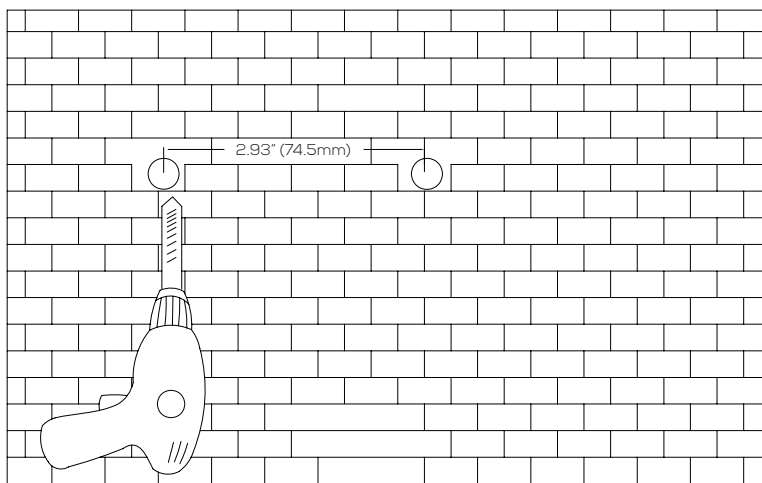

Step 2

Use the nuts to fix the fixture to the wall aiming at the expansion screws, and adjust angle of the bracket and tighten the small screw on the side, then connect the AC wire.

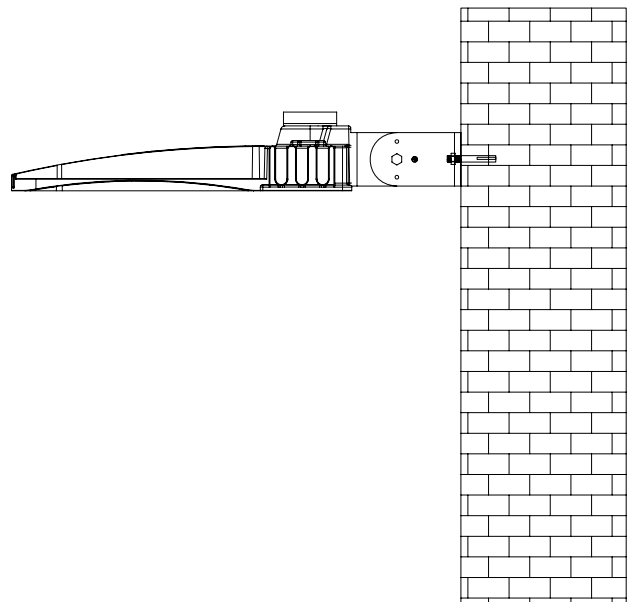

MOUNTING GUIDES

III A1: ARM MOUNTING FOR SQUARE POLE

Arm dimensions

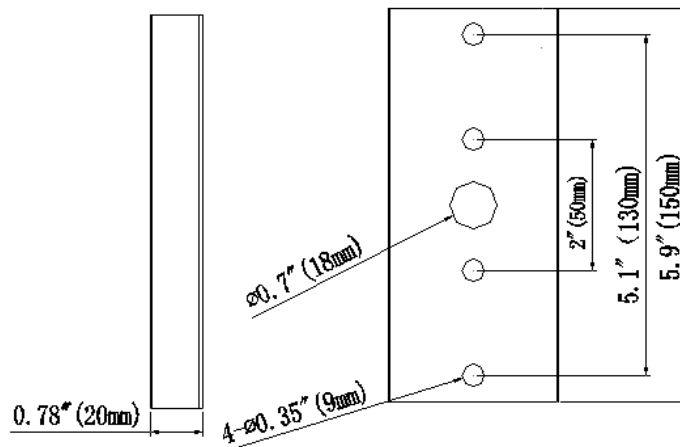
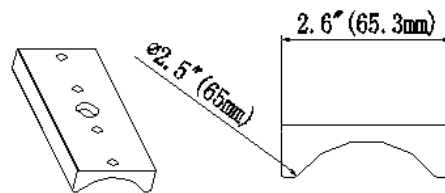
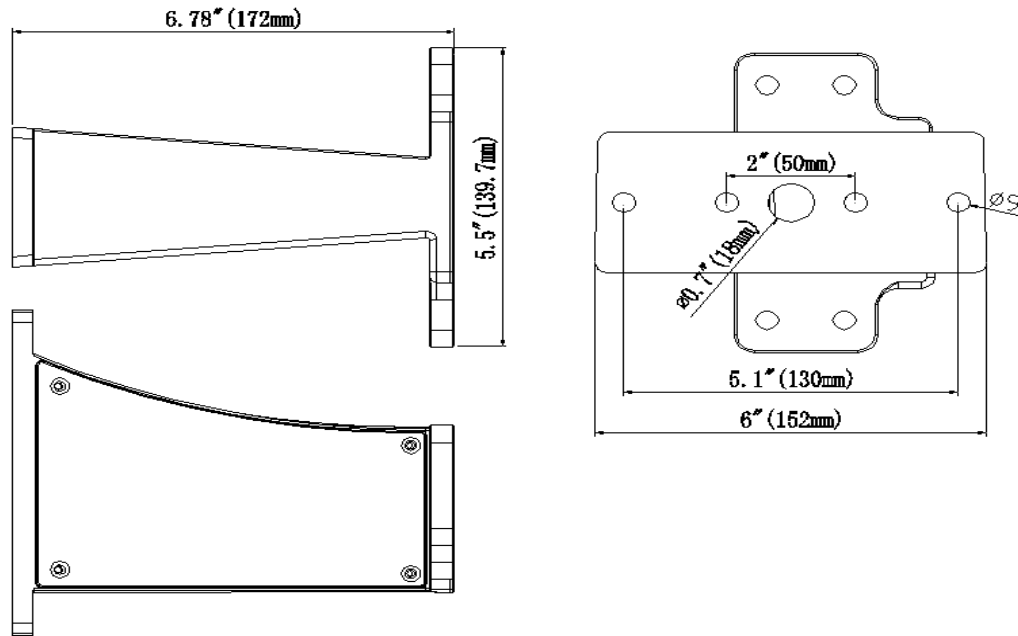

MOUNTING GUIDES

Arm assembly drawing

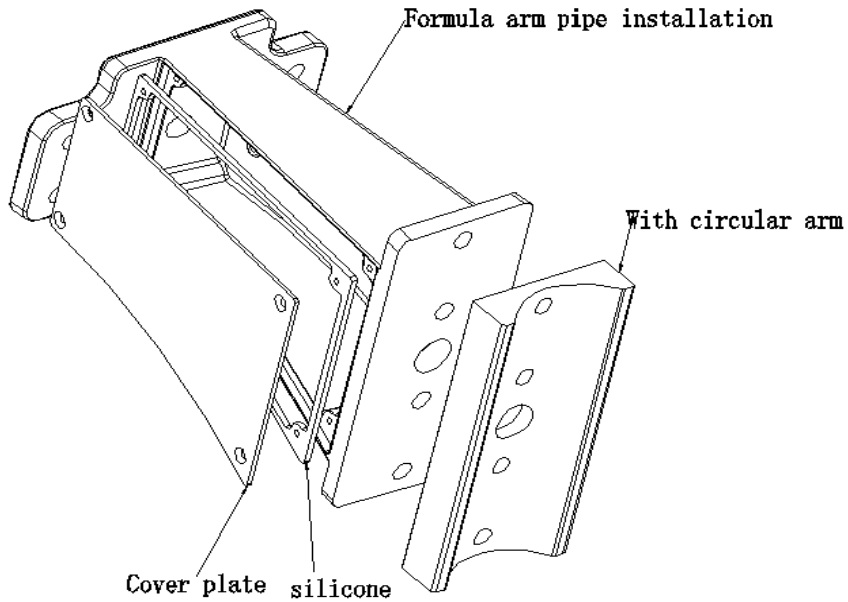

Step 1

Drill holes on the square pole corresponding to the holes on the arm, and use the bolt and nut plate to fix the fixture to the pole tightly.

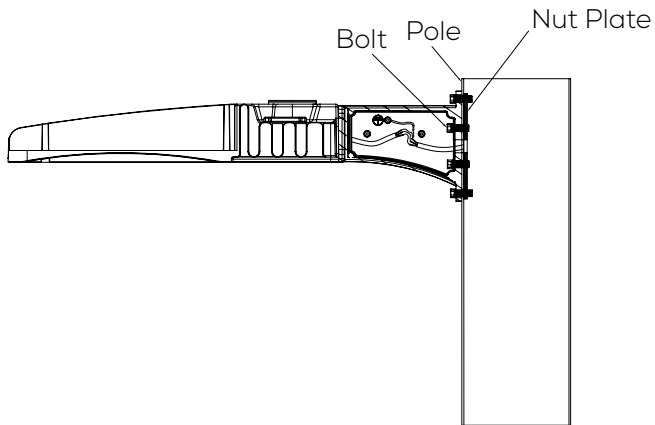

Step 2

Connect the AC wire of the fixture and tighten the water-proof gasket and cover plate on the arm by screws, then power on.

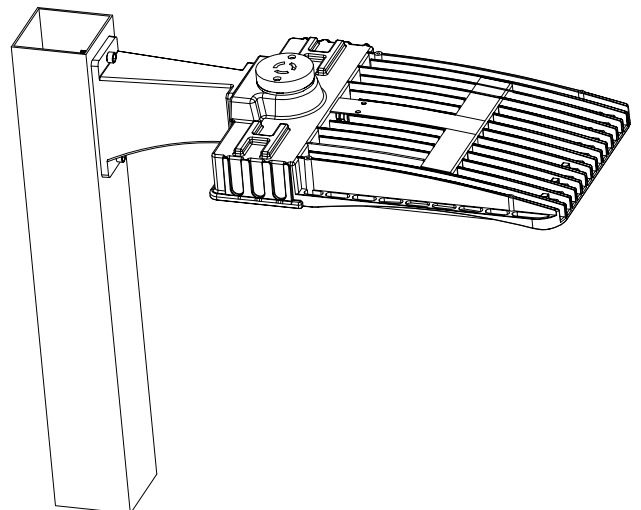

MOUNTING GUIDES

IV A2: ARM MOUNTING FOR ROUND POLE

Step 1

Drill holes on the round pole corresponding to the holes on the arm, and use the bolt and nut plate to fix the fixture to the pole tightly.

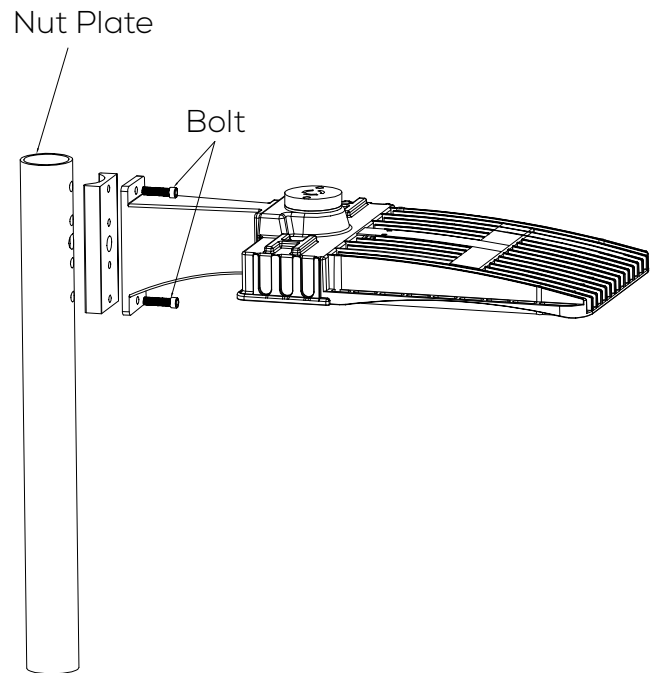

Step 2

Connect the AC wire of the fixture and tighten the water-proof gasket and cover plate on the arm by screws, then power on.

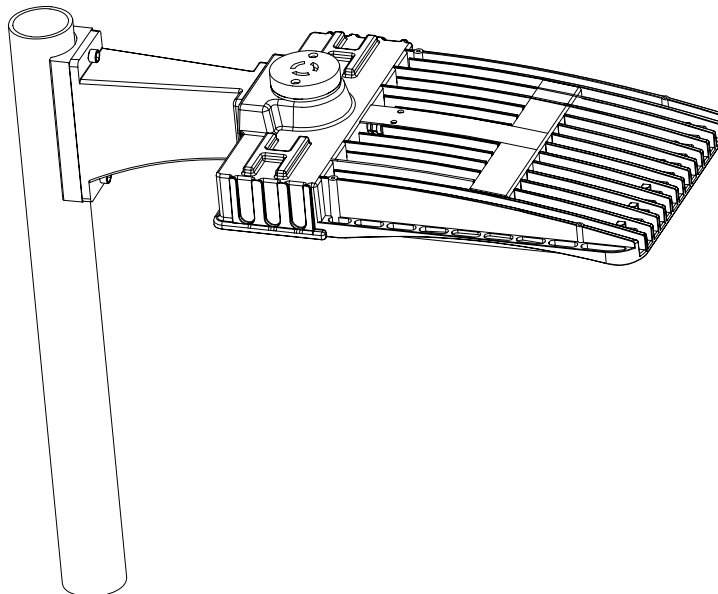

MOUNTING GUIDES

ARM With Microwave Sensor

Step 1 Check if the work voltage of microwave sensor, photocell and shorting cap conform to input voltage, then turn on to test the microwave sensor.

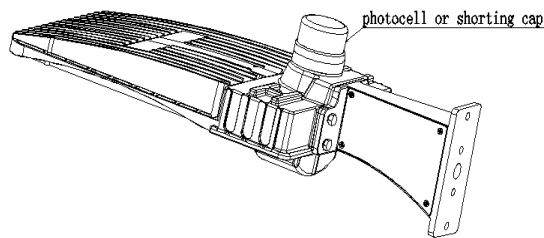

Step 2 If it didn't work, open the waterproof box and set the microwave sensor to work, lock the box after completed. (Attention put in the water-proof gasket before lock).

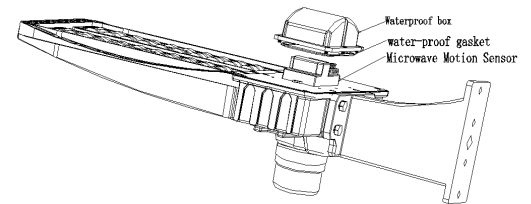

Replace shorting Cap with microwave sensor by Photocell with microwave sensor

Step 1 Check if the work voltage of microwave sensor and photocell conform to input voltage, then take off the shorting cap.

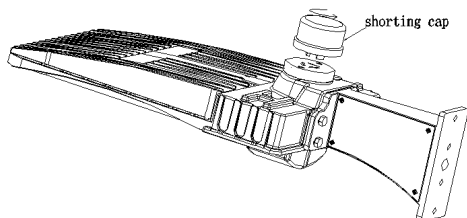

Step 2 Connect the photocell with the base.

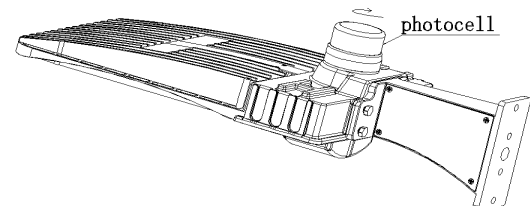

MOUNTING GUIDES

Wiring diagram as below.

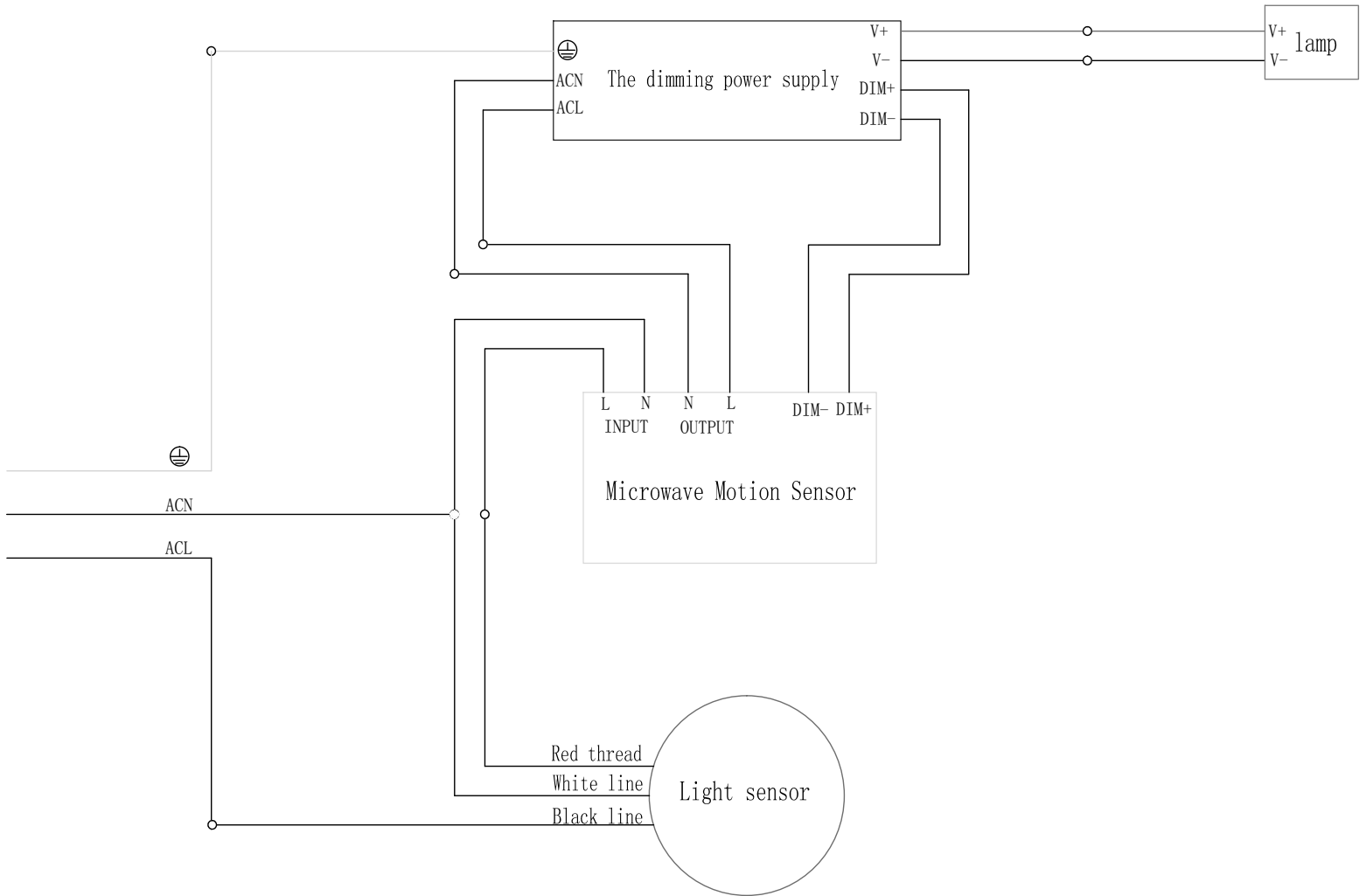

MOUNTING GUIDES

Microwave Sensor Wiring diagram

Detection zone:Max. (DXH) :16mX15m

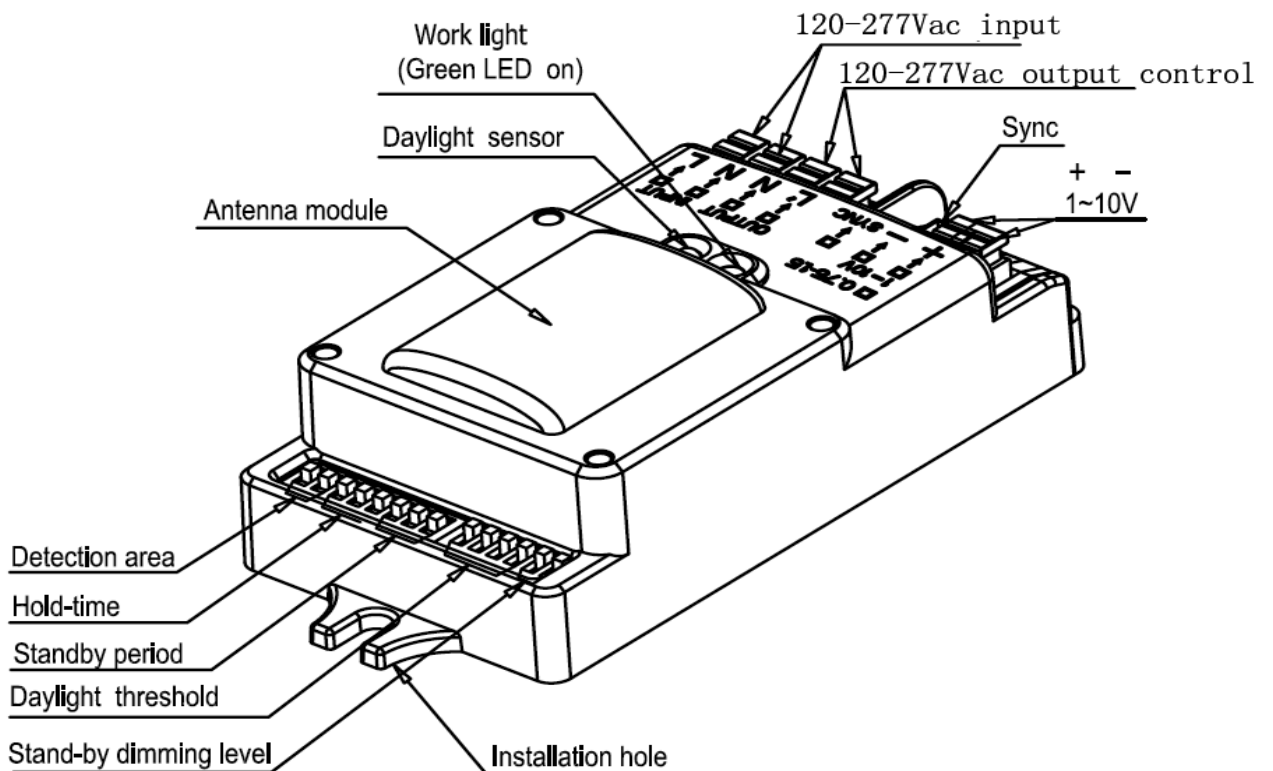
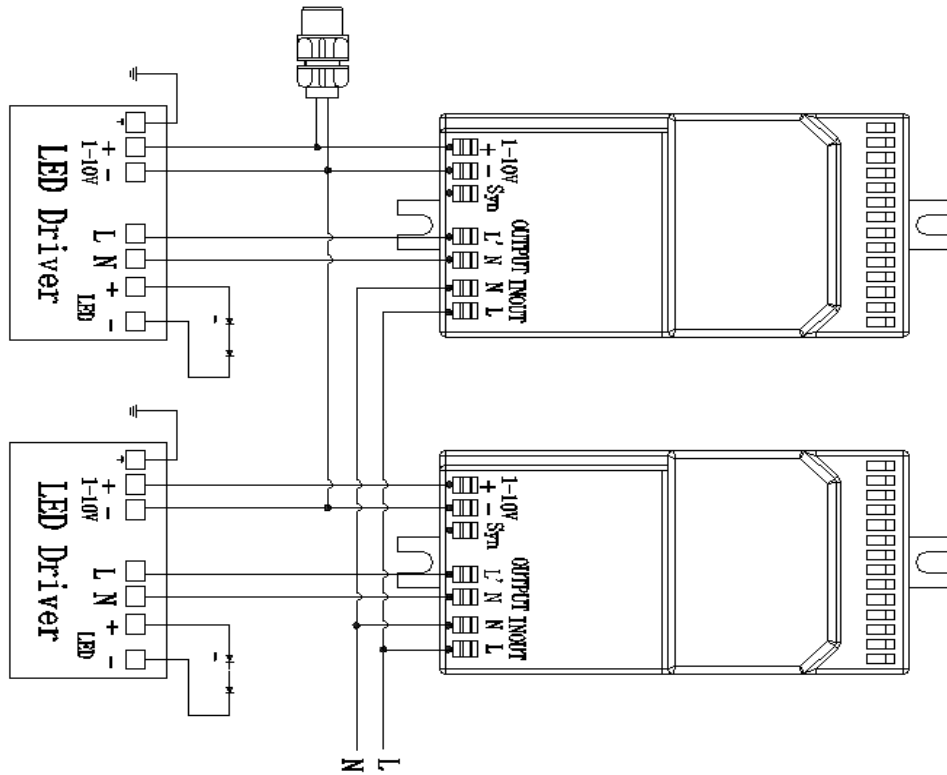

MOUNTING GUIDES

setting

By selecting the combination on the DIP switches, sensor data can be precisely set for each specific application.

ON ↑ [DIP SWITCH]		1	2	
	I	ON	ON	100%
	II	ON	-	75%
	III	-	ON	50%
	IV	-	-	10%

Detection area

Detection area can be reduced by selecting the combination on the DIP switches to fit precisely each application .

ON ↑ [DIP SWITCH]		3	4	5	
	I	ON	ON	ON	5s
	II	-	ON	ON	30s
	III	ON	-	ON	90s
	IV	-	-	ON	3min
	V	ON	ON	-	20min
VI	-	-	-	30min	

Hold time

Refers to the time period the lamp remains at 100% illumination after no motion detected.

ON ↑ [DIP SWITCH]		6	7	8	
	I	ON	ON	ON	0s
	II	-	ON	ON	5s
	III	ON	-	ON	5min
	IV	-	-	ON	10min
	V	ON	ON	-	30min
	VI	-	ON	-	1h
VII	-	-	-	+∞	

Stand-by period

Refers to the time period the lamp remains at a low light level before it completely switches off in the long absence of people.
When set to "+∞" mode, the low light is maintained until motion is detected.

ON ↑ [DIP SWITCH]		1	2	3	4	
	I	-	-	ON	ON	2Lux
	II	-	-	-	ON	5Lux
	III	-	ON	ON	-	10Lux
	IV	-	-	ON	-	25Lux
	V	-	ON	-	-	50Lux
	VI	ON	-	-	-	100Lux
VII	-	-	-	-	Disable	

Daylight sensor

The sensor can be set to only allow the lamp to illuminate below a defined ambient brightness threshold.
When set to Disable mode, the daylight sensor will switch on the lamp when motion is detected regardless of ambient light level.
50lux, 30lux: twilight operation, 10lux, 5lux: darkness operation only.
Note that daylight sensor is active only when lamp totally switches off.

ON ↑ [DIP SWITCH]		5	6	
	I	ON	ON	50%
	II	-	ON	30%
	III	ON	-	20%
IV	-	-	10%	

Stand-by dimming level

The low light level you would like to have after the hold time in the long absence of people.

MOUNTING GUIDES

QUALITY ASSURANCE

- Quality assurance is based on proper storage, transportation, installation, using and maintenance
- Damages caused by man-made mistake or improper use are not covered by the warranty
- Risk of electrical shock!
- During the warranty period, the manufacturer will provide appropriate support and repair service according to the actual situation

WARNINGS AND CAUTIONS

- The product must be installed according to the instructions. Installed by a person familiar with the product, production and product hazards.
- Avoid fire and electric shock. When install the lighting fixtures, you need to understand the electrical characteristics. If you are not sure, do not attempt to install. Please contact the electrician.
- Understand the structural features and dimensions of lighting before installation
- Do not drill holes or change internal lines when install